

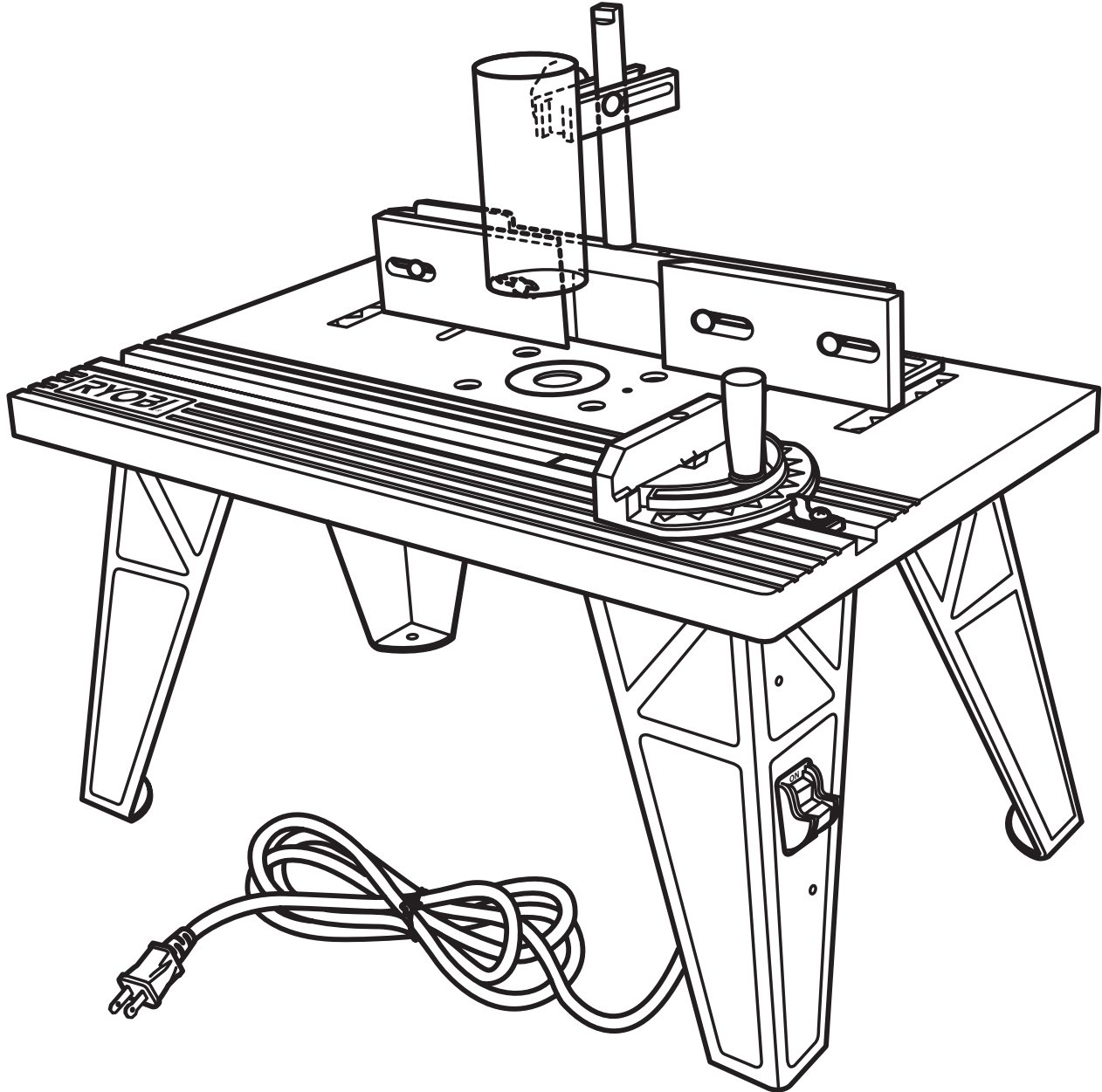

OPERATOR'S MANUAL

ROUTER TABLE

RT101 - DOUBLE INSULATED



For use only with the Ryobi R161 or R162 router (includes R1801M1 motor with R181FB1 base)

Your new router table has been engineered and manufactured to Ryobi's high standard for dependability, ease of operation, and operator safety. Properly cared for, it will give you years of rugged, trouble-free performance.

⚠ WARNING: To reduce the risk of injury, the user must read and understand the operator's manual.

Thank you for buying a Ryobi router table.

SAVE THIS MANUAL FOR FUTURE REFERENCE

TABLE OF CONTENTS

■ Introduction	2
■ Rules for Safe Operation	3-4
■ Symbols	5
■ Specifications	6
■ Unpacking	6
■ Features	7
■ Assembly	9-12
■ Adjustments	13-15
■ Operation	15-16
■ Maintenance	16
■ Parts, Ordering, and Service	18

INTRODUCTION

Your router table has many features for making the use of a router more pleasant and enjoyable. Safety, performance, and dependability have been given top priority in the design of this router table making it easy to maintain and operate.

WARNING:

Do not attempt to use this product until you have read thoroughly and understand completely the operator's manual. Pay close attention to the safety rules, including Dangers, Warnings, and Cautions. If you use your router table properly and only for what it is intended, you will enjoy years of safe, reliable service.



The operation of any power tool can result in foreign objects being thrown into your eyes, which can result in severe eye damage. Before beginning tool operation, always wear safety goggles or safety glasses with side shields and a full face shield when needed. We recommend Wide Vision Safety Mask for use over eyeglasses or standard safety glasses with side shields. Always wear eye protection which is marked to comply with ANSI Z87.1.



Look for this symbol to point out important safety precautions. It means attention!!! Your safety is involved.

RULES FOR SAFE OPERATION

Safe operation of this power tool requires that you read and understand this operator's manual and all labels affixed to the tool. Safety is a combination of common sense, staying alert, and knowing how your tool works.

READ ALL INSTRUCTIONS

- **Know your power tool. Read operator's manual carefully. Learn its applications and limitations, as well as the specific potential hazards related to this tool.** Following this rule will reduce the risk of electric shock, fire, or serious injury.
- **Keep guards in place** and in good working order.
- **Remove wrenches and adjusting keys.** Form the habit of ensuring that hex keys and adjusting wrenches are removed **before** turning on the tool.
- **Keep the work area clean.** Cluttered work areas and work benches invite accidents.
- **Do not use in dangerous environments.** Do not use power tools in damp or wet locations, or expose them to rain. Keep the work area well lit.
- **Keep children and visitors away.** All visitors should be kept a safe distance from work area.
- **Make workshop childproof** with padlocks and master switches or by removing starter keys.
- **Do not force the tool.** It will do the job better and safer at the rate for which it was designed.
- **Use the right tool.** Do not force the tool or attachment to do a job for which it was not designed.
- **Use the proper extension cord.** Make sure your extension cord is in good condition. Use only a cord heavy enough to carry the current your product will draw. An undersized cord will cause a drop in line voltage resulting in loss of power and overheating. A wire gage size (A.W.G.) of at least 14 is recommended for an extension cord 25 feet or less in length. If in doubt, use the next heavier gage. The smaller the gage number, the heavier the cord.
- **Inspect tool cords periodically and, if damaged, have repaired at your nearest authorized service center. Constantly stay aware of cord location.** Following this rule will reduce the risk of electric shock or fire.
- **Do not abuse cord. Never carry the tool by the cord or yank it to disconnect it from the receptacle. Keep cord away from heat, oil, and sharp edges.** Following this rule will reduce the risk of electric shock or fire.
- **Polarized plugs.** To reduce the risk of electric shock, this equipment has a polarized plug (one blade is wider than the other). This plug will fit in a polarized outlet only one way. If the plug does not fit fully in the outlet, reverse the plug. If it still does not fit, contact a qualified electrician to install the proper outlet. Do not change the plug in any way.
- **Wear proper apparel.** Do not wear loose clothing, gloves, neckties, rings, bracelets, or other jewelry that can get caught in moving parts. Non-slip footwear is recommended. Also wear protective hair covering to contain long hair.
- **Always wear safety glasses.** Everyday eyeglasses have only impact-resistant lenses; they are **NOT** safety glasses.
- **Protect your lungs. Wear a face or dust mask if the operation is dusty.** Following this rule will reduce the risk of serious personal injury.
- **Protect your hearing. Wear hearing protection during extended periods of operation.** Following this rule will reduce the risk of serious personal injury.
- **Secure work.** Use clamps or a vise to hold work when practical. It is safer than using your hand and frees both hands to operate tool.
- **Do not overreach.** Keep proper footing and balance at all times.
- **Never stand on tool.** Serious injury could occur if the tool is tipped or if the cutting tool is unintentionally contacted.
- **Maintain tools with care.** Keep tools sharp and clean for better and safer performance. Follow instructions for lubricating and changing accessories.
- **Avoid accidental starting.** Make sure switch is in off position when plugging in tool.
- **Disconnect tools before servicing,** when not in use, or when changing attachments.
- **Use recommended accessories.** Consult the operator's manual for recommended accessories. The use of improper accessories may cause risk of injury.

RULES FOR SAFE OPERATION

- **Check damaged parts.** Before using the tool, a guard or other part that is damaged should be carefully checked to determine that it will operate properly and perform its intended function. Check for alignment of moving parts, binding of moving parts, breakage of parts, mounting and any other conditions that may affect its operation. A guard or other part that is damaged must be properly repaired or replaced.
- **Direction of feed.** Feed work into a blade or cutter against the direction or rotation of the blade or cutter only.
- **Keep hands away from cutting area.** Do not reach underneath the table or in the cutting path with your hands or fingers at any time while the tool is connected to a power source.
- **Do not use awkward hand positions.**
- **Use overhead guard when adjustable fence is not in place.**
- **Firmly clamp or bolt the router table to a work surface** so that the router table surface is approximately hip height.
- **Never leave tool running unattended. Turn the power off.** Do not leave tool until it comes to a complete stop.
- **Inspect for and remove all nails from lumber before routing.** Following this rule will reduce the risk of serious personal injury.
- **Drugs, alcohol, medication. Do not operate tool while under the influence of drugs, alcohol, or any medication.** Following this rule will reduce the risk of electric shock, fire, or serious personal injury.
- **Save these instructions. Refer to them frequently and use them to instruct others who may use this tool. If you loan someone this tool, loan them these instructions also.**

WARNING:



Some dust created by power sanding, sawing, grinding, drilling, and other construction activities contains chemicals known to cause cancer, birth defects or other reproductive harm. Some examples of these chemicals are:

- lead from lead-based paints,
- crystalline silica from bricks and cement and other masonry products, and
- arsenic and chromium from chemically-treated lumber.

Your risk from these exposures varies, depending on how often you do this type of work. To reduce your exposure to these chemicals: work in a well ventilated area, and work with approved safety equipment, such as those dust masks that are specially designed to filter out microscopic particles.

SYMBOLS

Important: Some of the following symbols may be used on your tool. Please study them and learn their meaning. Proper interpretation of these symbols will allow you to operate the tool better and safer.

SYMBOL	NAME	DESIGNATION/EXPLANATION
V	Volts	Voltage
A	Amperes	Current
Hz	Hertz	Frequency (cycles per second)
W	Watt	Power
min	Minutes	Time
~	Alternating Current	Type or a characteristic of current
n_0	No Load Speed	Rotational speed, at no load
	Class II Construction	Designates double-insulated construction tools
.../min	Revolutions or Reciprocation Per Minute	Revolutions, strokes, surface speed, orbits etc. per minute
	Safety Alert	Indicates danger, warning or caution. It means attention!!! Your safety is involved.
	Wet Conditions Alert	Do not expose to rain or use in damp locations.

The purpose of safety symbols is to attract your attention to possible dangers. The safety symbols, and the explanations with them, deserve your careful attention and understanding. The safety warnings do not by themselves eliminate any danger. The instructions or warnings they give are not substitutes for proper accident prevention measures.

SYMBOL MEANING



DANGER: Failure to obey a safety warning will result in serious injury to yourself or to others. Always follow the safety precautions to reduce the risk of fire, electric shock and personal injury.



WARNING: Failure to obey a safety warning can result in serious injury to yourself or to others. Always follow the safety precautions to reduce the risk of fire, electric shock and personal injury.



CAUTION: Failure to obey a safety warning may result in property damage or personal injury to yourself or to others. Always follow the safety precautions to reduce the risk of fire, electric shock and personal injury.

NOTE: Advises you of information or instructions vital to the operation or maintenance of the equipment.

SAVE THESE INSTRUCTIONS

SPECIFICATIONS

Table Dimensions	14 in. x 24 in. (35.6 cm x 61 cm)
Maximum Cutter Diameter	1-15/16 in. (4.9 cm)
Fence Length	16 in. (40.64 cm)
Miter Slot	3/8 in. x 3/4 in. x 24 in. (0.9 cm x 1.9 cm x 61 cm)
Rating	120 Volts, 60 Hz, AC only
Net Weight	18 lbs. (8.2 kg.)

UNPACKING

INFORMATION

- Carefully remove the parts from the box. Make sure that all items listed in the packing list are included.
- Inspect the parts carefully to make sure no breakage or damage occurred during shipping.
- Do not discard the packing material until you have carefully inspected and satisfactorily operated the product.
- If any parts are damaged or missing, please call 1-800-525-2579 for assistance.

⚠ WARNING:

If any parts are missing do not operate the product until the missing parts are replaced. Failure to do so could result in serious personal injury.

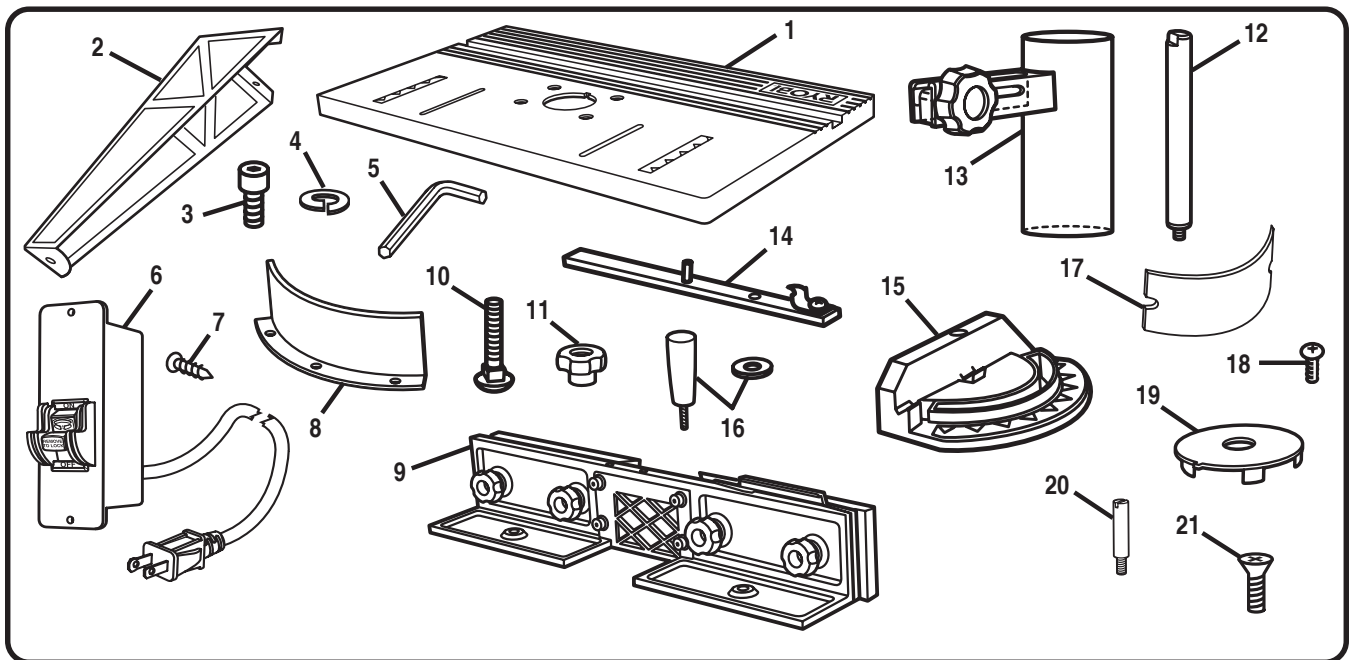

PACKING LIST

1. Router table surface (1)
2. Table leg (4)
3. Socket head screw (19)
4. Lock washer (19)
5. Hex key (1)
6. Switch box assembly (1)
7. Thread cutting screw (2)
8. Undertable guard (1)
9. Fence assembly (1)
10. Carriage bolt (2)
11. Fence lock knob (2)
12. Guard post (1)
13. Cutter guard assembly (1)
14. Miter gauge bar (1)
15. Miter gauge (1)
16. Miter gauge knob & washer (1 ea)
17. Rear safety guard (1)
18. Pan head machine screw (2)
19. Throat plate (5)
20. Starting pin
21. Flat head machine screw (3)

FEATURES

DOUBLE INSULATION

Double insulation is a concept in safety in electric power tools, which eliminates the need for the usual three-wire grounded power cord. All exposed metal parts are isolated from the internal metal motor components with protecting insulation. Double insulated tools do not need to be grounded.

WARNING:

The double insulated system is intended to protect the user from shock resulting from a break in the tool's internal wiring. Observe all normal safety precautions to avoid electrical shock.

Important: Servicing of a tool with double insulation requires extreme care and knowledge of the system and should be performed only by a qualified service technician. For service, we suggest you return the tool to your nearest authorized service center for repair. Always use original factory replacement parts when servicing.

SWITCH

The router table has a conveniently located toggle switch. In addition, the router table is equipped with a switch key. You must insert the key to turn the switch on. If you remove the key during operation, you can turn the switch off, but you may not turn it on again until you replace the key.

FENCE ASSEMBLY

The fence assembly provides an adjustable surface to support and guide the work.

STARTING PIN

When you are unable to use the fence for a guide because the workpiece is odd-shaped or too small, use the starting pin for a guide. Only use piloted cutters when using the starting pin.

CUTTER GUARD/VACUUM ATTACHMENT

The cutter guard provides a barrier to protect the operator from contact with the cutter and is adjustable for all types of cuts and materials. The cutter guard also doubles as a vacuum attachment. You can insert a standard shop vacuum into the top of the clear plastic ring to keep dust down to a minimum.

MITER GAUGE

A miter gauge is used for mitered routing and to help support wider pieces.

GUARDS

The undertable guard and rear safety guard ensure that your hand, loose clothing, and other objects do not come in contact with the cutter or collet during operation.

WARNING:

The undertable guard and rear safety guard must be securely in place before using the router table. Failure to do so could result in serious personal injury.

THROAT PLATES

Five throat plates are included with the router table. The throat plate provides a stable surface around the cutter and prevents objects from falling through the throat and damaging the spindle.

WARNING:

Do not allow familiarity with your router or router table to make you careless. Remember that a careless fraction of a second is sufficient to inflict severe injury.

FEATURES

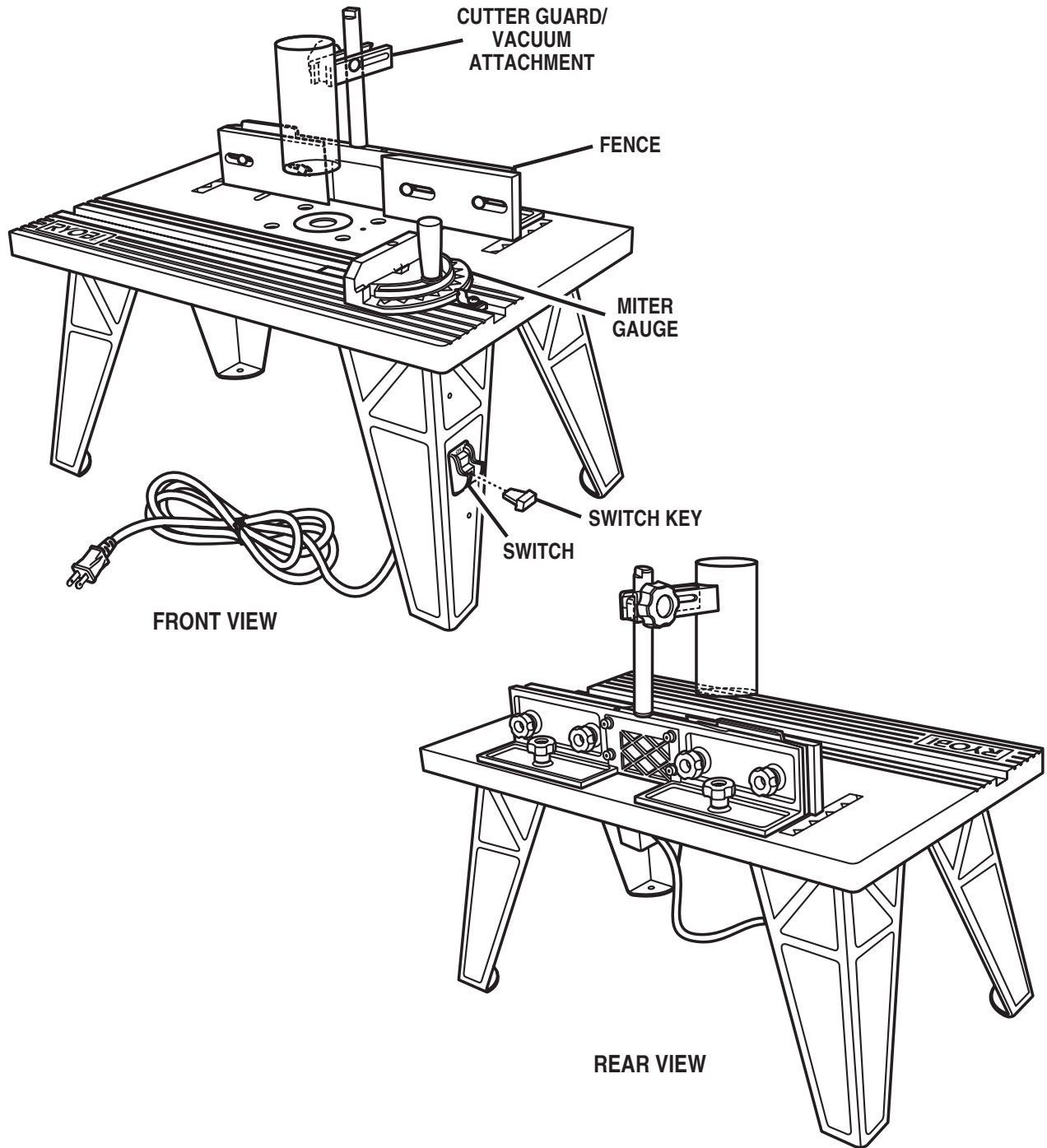

Fig. 1

⚠ WARNING:

Do not attempt to modify this tool or create accessories not recommended for use with this tool. Any such alteration or modification is misuse and could result in a hazardous condition leading to possible serious personal injury.

ASSEMBLY

⚠ WARNING:

The router or router table should never be connected to a power supply when you are assembling parts, making adjustments, installing or removing cutters, cleaning, or when not in use. Disconnecting the router and router table will prevent accidental starting that could cause serious personal injury.

ASSEMBLING THE ROUTER TABLE

Assembling the router table involves attaching the legs, the undertable guard, the switch box, the fence, the cutter guard/vacuum attachment, and the miter gauge to the router table.

TO ATTACH THE LEGS

See Figure 2.

Follow these directions to attach the legs.

- Place router table surface upside down on a flat, level surface with the front edge closest to you.
- Place each leg in a corner of the table.

NOTE: Two of the legs have been keyed for proper placement. With the table surface upside down, place the leg with four holes and two punched notches in the front left corner of the table and the leg with six holes in the front right corner of the table.

- Align the four holes in the legs with the four corresponding threaded holes in the table.
- Use the hex key to secure each leg with four socket head screws and lock washers.

TO ATTACH THE SWITCH BOX

See Figure 3.

Follow these directions to attach the switch box.

- Place the router table upside down on a flat surface.
- Hold the switch box so that the words **ON** and **OFF** on the toggle switch are upside down.
- Insert the switch box through the cutout in the left front leg.
- Align the two small holes in the mounting tabs with the two small holes in the leg.
- Use a screwdriver to secure the switch box with two thread cutting screws.

TO ATTACH THE UNDERTABLE GUARD

See Figure 4.

Follow these directions to attach the undertable guard.

- Place the router table upside down on a flat surface.
- Position the undertable guard around the throat of the table.
- Align the three holes of the guard with the threaded holes in the table.
- Use the hex key to secure the undertable guard with three socket head screws and lock washers.

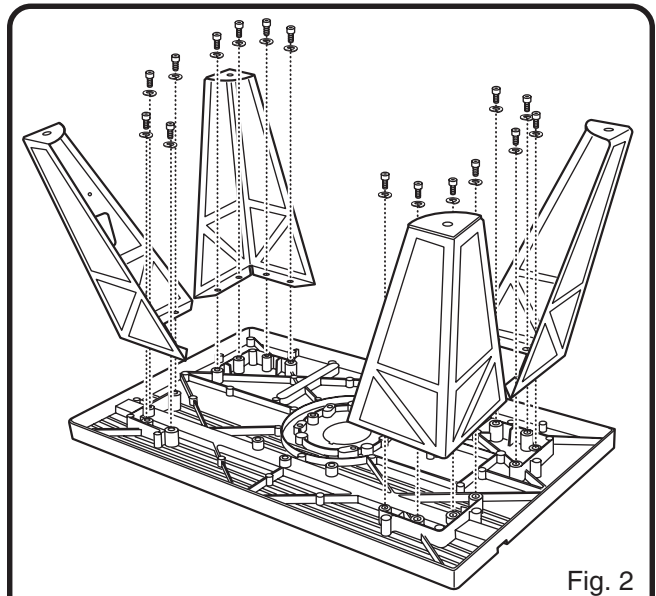

Fig. 2

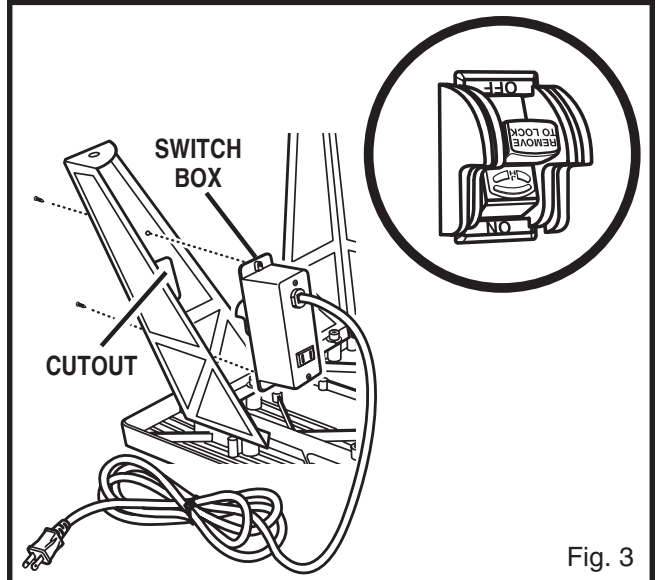

Fig. 3

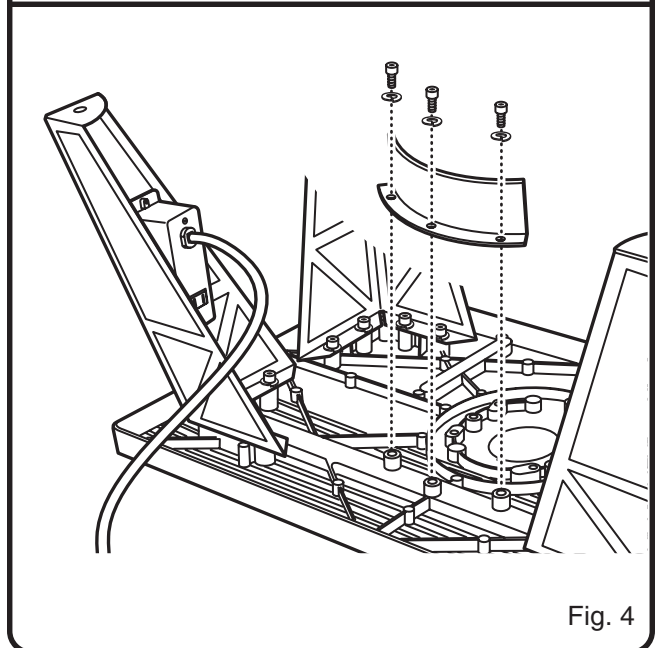

Fig. 4

ASSEMBLY

TO ATTACH THE FENCE

See Figure 5.

Follow these directions to attach the fence.

- Place the router table right side up with the back edge closest to you.
- Position the fence on the table with the four black knobs facing you.
- Align the two holes on the bottom of the fence with the two channels on the router table.
- Secure the fence to the table with the two fence lock knobs and carriage bolts.

TO ATTACH THE CUTTER GUARD ASSEMBLY/ VACUUM ATTACHMENT

See Figure 6.

Follow these directions to attach the cutter guard assembly/vacuum attachment.

- Place the router table right side up with the back edge closest to you.
- Screw the guard post securely into one of the threaded holes on the top of the fence.

NOTE: When the fence is close to the cutter, place the guard post in the off-center threaded hole to provide protection from the cutter and allow for proper suction for the vacuum.

- Loosen the clear plastic ring by turning the black knob counterclockwise.
- Slide the ring over the guard post.
- Center the cutter guard over the throat of the router table.
- Tighten the cutter guard by turning the black knob clockwise.

NOTE: While routing, you can insert a standard shop vacuum into the top of the clear plastic ring to keep dust down to a minimum.

TO ATTACH THE MITER GAUGE

See Figure 7.

Follow these directions to attach the miter gauge.

- Place the router table right side up with the front edge closest to you.
- Place the miter gauge bar in the track near the front of the table with the pointer on the right.
- Position the miter gauge onto the miter gauge bar placing the miter gauge under the pointer and aligning the hole in the miter gauge over the small post in the miter gauge bar.
- Screw the miter gauge knob into the threaded hole in the miter gauge bar.

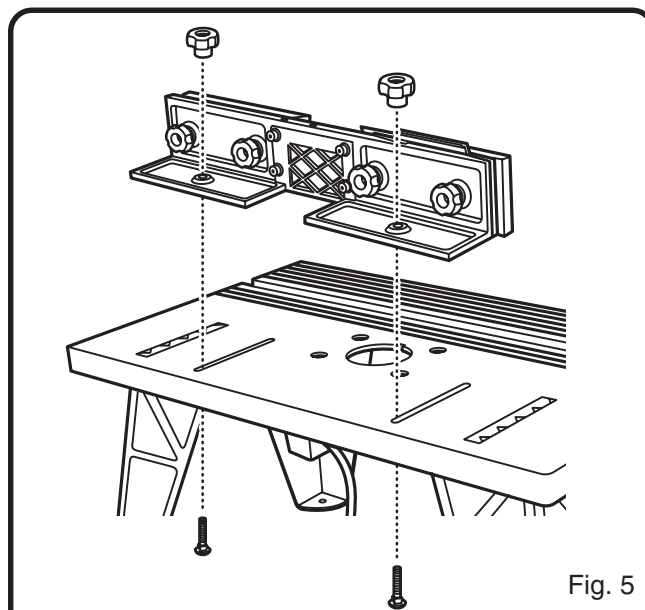

Fig. 5

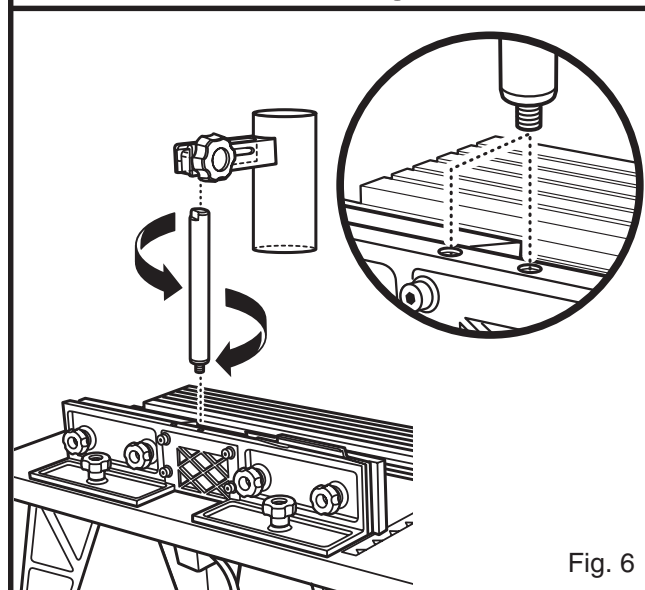

Fig. 6

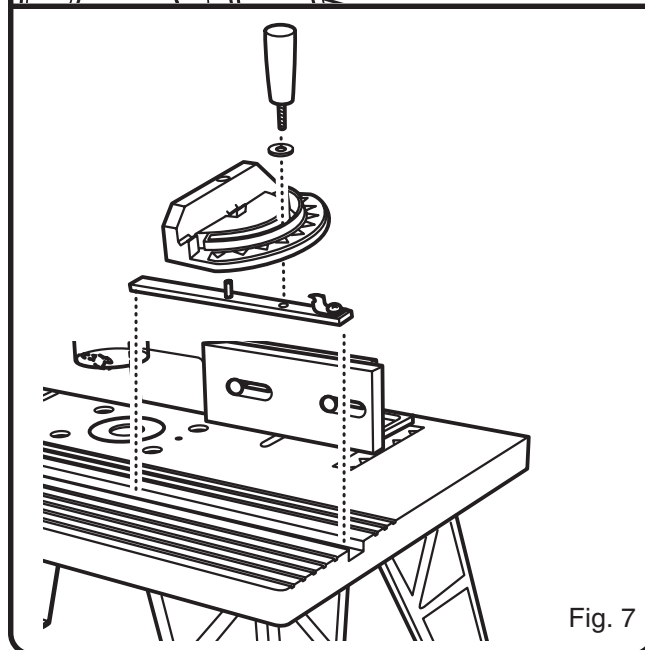

Fig. 7

ASSEMBLY

ATTACHING THE REAR SAFETY GUARD TO THE ROUTER

See Figure 8.

Follow these directions to attach the rear safety guard to the router.

- Place the rear safety guard on the back of the router.
- Align the slots in the guard with the holes in the router.
- Secure the rear safety guard to the router with the two machine screws.

ATTACHING THE ROUTER TO THE TABLE

Attach the router to the router table after you have assembled the table and installed the rear safety guard.

See Figure 9.

Follow these directions to attach the router to the table.

- Place the router table right side up with the front edge closest to you.
- Be sure the table is stable and rests on all four legs.
- Hold the router upside down so that the front of the router faces you.
- Align the holes in the center of the table with the holes in the router.

NOTE: To attach router, use the two right holes and the back left hole.

- Hold the router with one hand and securely tighten each of the machine screws with the other hand.

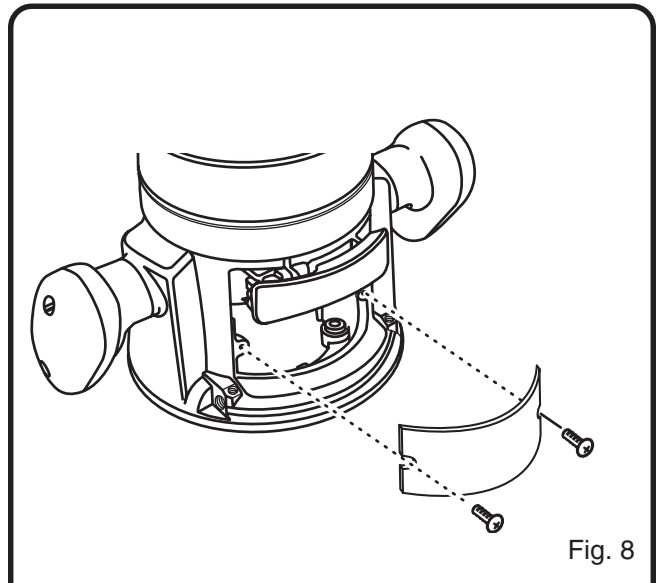

Fig. 8

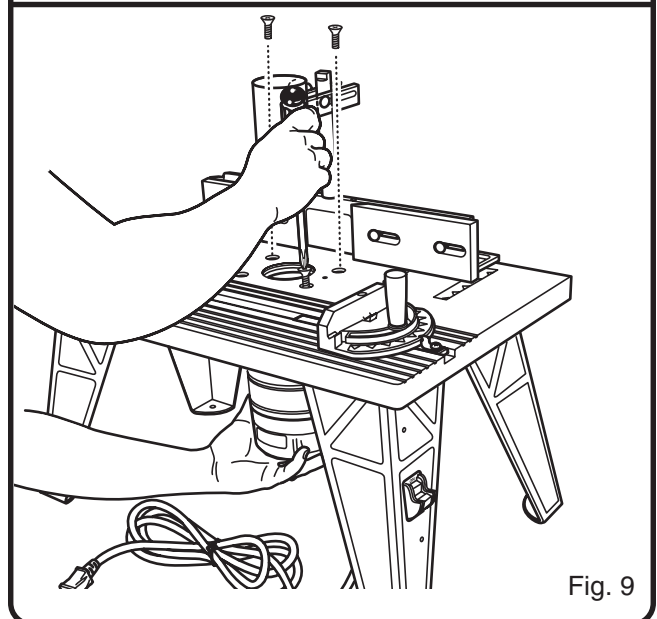

Fig. 9

ASSEMBLY

MOUNTING THE TABLE TO A WORK SURFACE

See Figure 10a and 10b.

Follow these directions to mount the table to a work surface.

- Place the router table right side up on a sturdy work surface, e.g., work stand, workbench, counter top.
- Mark the holes with a pencil.
- Remove the router table.
- Drill four holes through the work surface.
- Place the router table back on the work surface, aligning the holes in the table legs with the holes in the work surface.

NOTE: Position the router table surface at approximately hip height.

- Insert four bolts (not included, 1/4-20 recommended) and tighten securely with lock washers and hex nuts (not included).

NOTE: If you plan to transport the router table to different locations, we recommend that you attach it permanently to a mounting board that you can easily clamp to a work surface.

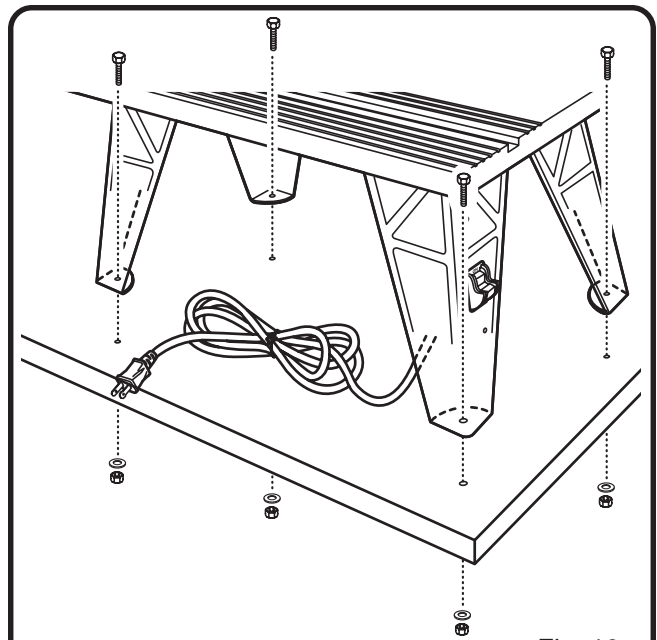

Fig. 10a

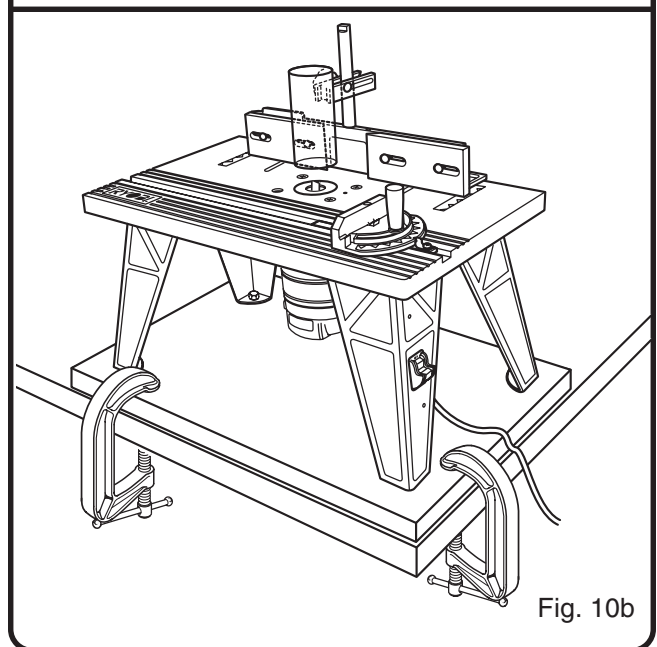

Fig. 10b

ADJUSTMENTS

⚠ WARNING:

The router or router table should never be connected to a power supply when you are assembling parts, making adjustments, installing or removing cutters, cleaning, or when not in use. Disconnecting the router and router table will prevent accidental starting that could cause serious personal injury.

INSERTING/REMOVING CUTTERS

Follow these directions to insert and remove cutters.

- Unplug the router and the router table.

⚠ WARNING:

Failure to unplug the router and router table could result in accidental starting causing serious injury.

⚠ WARNING:

To prevent damage to the spindle or spindle lock, always allow the motor to come to a complete stop before engaging the spindle lock.

- Remove the screws from the rear safety guard.
- Remove the rear safety guard from the router.
- Follow the directions for installing and removing cutters in the operator's manual.

⚠ WARNING:

Use this router table only with a Ryobi router. Do not attempt to use any other router with this table. Failure to heed this warning could result in improper operation of the tool and serious personal injury.

- Return the rear safety guard to its proper position.
- Secure the rear safety guard by inserting and tightening the two screws previously removed.

⚠ WARNING:

If you are changing a cutter immediately after use, be careful not to touch the cutter or collet with your hands or fingers. They will get burned because of the heat buildup from cutting. Always use the wrench provided.

ADJUSTING DEPTH OF CUT

See Figure 11.

We recommend that cuts be made at a depth not exceeding 1/8 in. (3.2 mm) and that several passes be made to reach depths of cut greater than 1/8 in. (3.2 mm).

Follow these directions to adjust depth of cut.

- Unplug the router and the router table.

⚠ WARNING:

Failure to unplug the router and router table could result in accidental starting causing serious injury.

- Unlock the clamping lever.
- Turn the depth adjusting ring until the tip of the cutter touches the work surface (zero depth of cut).
- Turn depth indicator ring to zero depth of cut on the scale.
- Turn the depth adjusting ring to the desired depth of cut.
- Lock the clamping lever securely.

NOTE: When you use certain cutters, you may need to remove the black plastic subbase from the router to achieve full depth of cut.

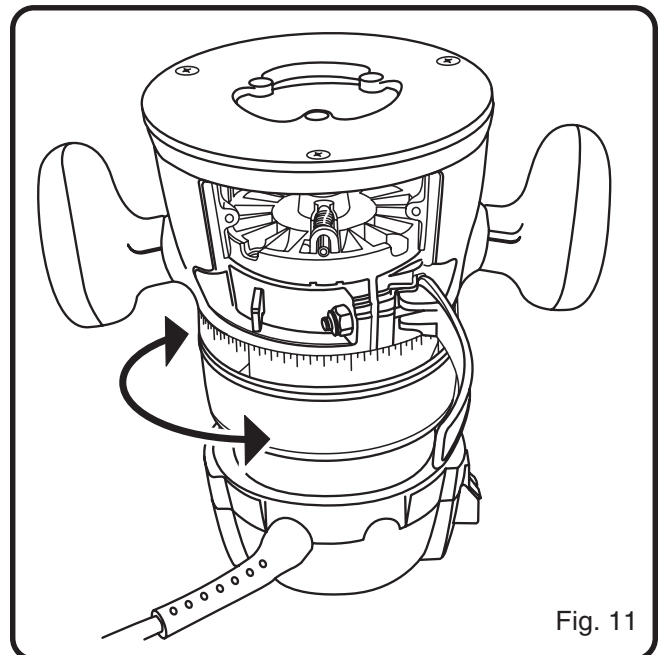

Fig. 11

ADJUSTMENTS

INSERTING THROAT PLATES

See Figure 12.

The throat plate provides a stable surface around the cutter and prevents objects from falling through the throat and damaging the spindle.

The proper size throat plate depends on the size and shape of the cutter. When inserted, the throat plate opening should be within approximately 1/4 in. (6.4 mm) of the outermost edge of the cutter.

Follow these directions to insert throat plates.

- Position the throat plate over the throat opening in the router table.
- Align the tab in the throat plate with the slot in the throat opening.
- Snap throat plate down and into place as shown.

NOTE: To remove throat plate, pull gently until the throat plate snaps out.

⚠ WARNING:

Never attempt to operate router table without the throat plate in place. Failure to do so could result in the workpiece jamming or objects falling into the rotating spindle, which could cause serious personal injury.

POSITIONING THE FENCE

The fence enables you to support and guide the workpiece.

See Figure 13.

Follow these directions to position the fence.

- Loosen the fence lock knobs.
- Position the fence the proper distance from the cutter based on the amount of material you plan to remove.
- Tighten the fence lock knobs.

ADJUSTING THE STEP RISERS

See Figure 14.

The step risers, located on the outfeed side of the fence, enable you to support the workpiece as it exits the cutter. The step risers provide support for routing operations that remove up to 1/8 in. (3.2 mm) of material. The step risers are adjustable in 1/32 in. (0.8 mm) increments.

Follow these directions to adjust the step risers.

- Loosen the knob bolts on the rear of the fence.
- Push the riser forward and toward the throat.
- Tighten the knob bolts.

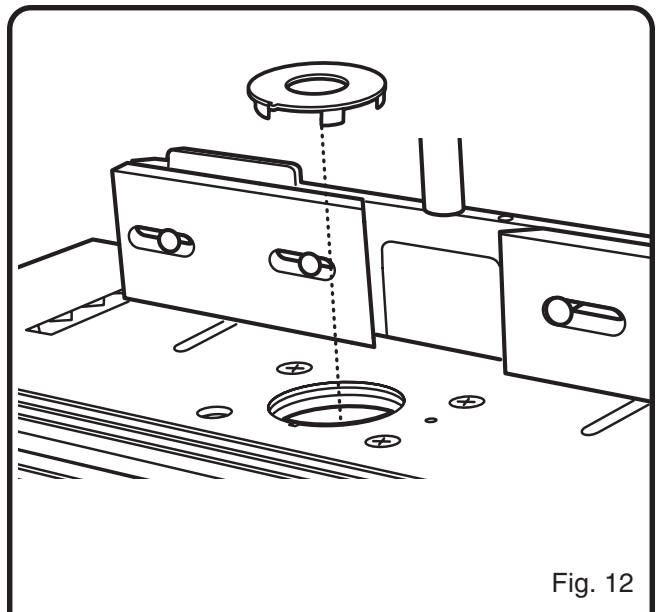

Fig. 12

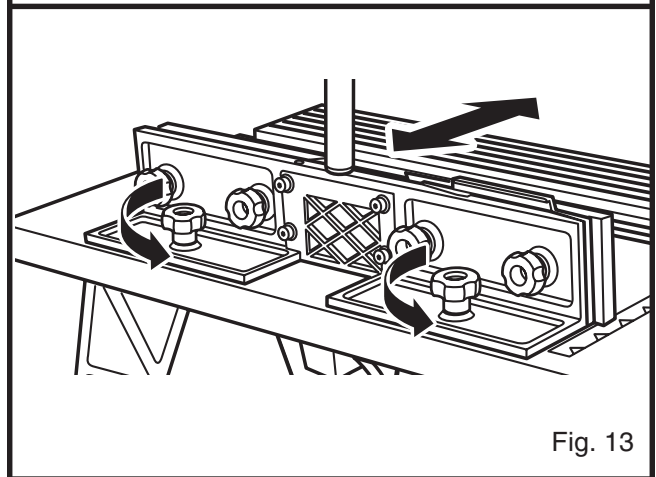

Fig. 13

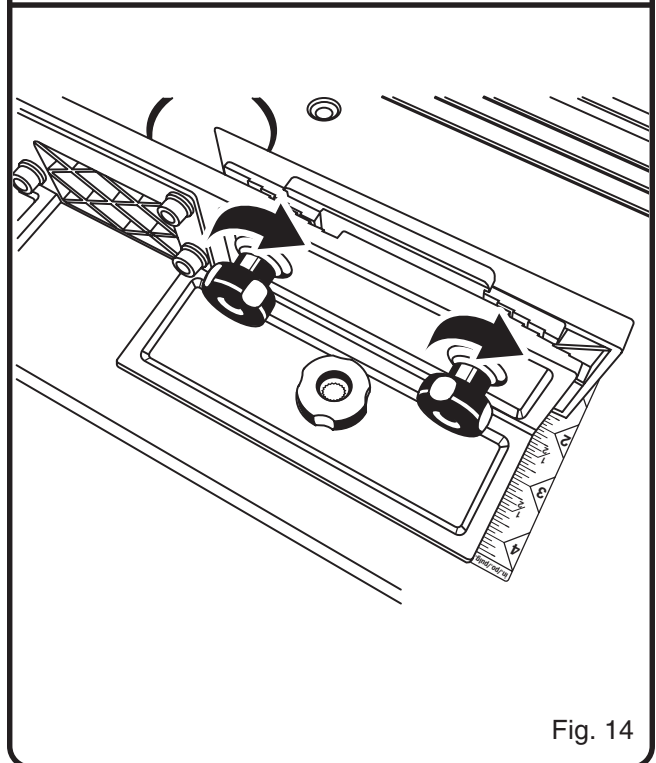

Fig. 14

ADJUSTMENTS

INSERTING THE STARTING PIN

Place the starting pin on the router table and use it as a pivot point when cutting small, odd-shaped pieces.

NOTE: It is not necessary to use the fence when you are using the starting pin. Additionally, only use piloted cutters when using the starting pin.

See Figure 15.

Follow these directions to insert the starting pin.

- Place the starting pin into the threaded hole to the right of the router table throat opening.
- Turn the pin clockwise to secure.

ADJUSTING THE MITER GAUGE

Follow these directions to adjust the miter gauge.

- Loosen the miter gauge knob.
- Rotate the miter gauge to the desired angle.
- Tighten the miter gauge knob.

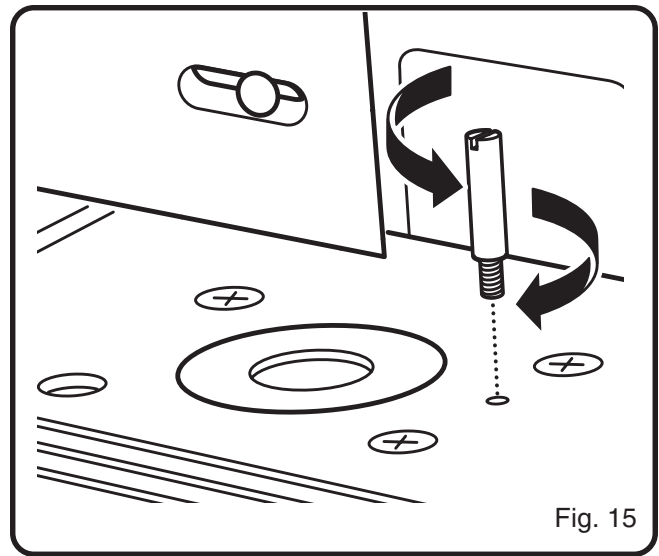

OPERATION

⚠ WARNING:

Always wear safety goggles or safety glasses with side shields when operating this tool. Failure to do so could result in dust, shavings, or loose particles being thrown into your eyes, resulting in serious injury.

USING THE ROUTER WITH THE ROUTER TABLE

Observe the following rules when using the router with the router table.

- Read the entire *Operator's Manual*.
- Always plug the router into the router table switched outlet. **Never** plug a router table mounted router into another power source.
- Lock-on the router switch. Refer to the *Operator's Manual* for details.
- Make sure the router table switch is off. Remove the switch key.
- Plug the router table power cord into a power source.
- Always control the power to the router with the router table switch whenever the router is mounted on the table.

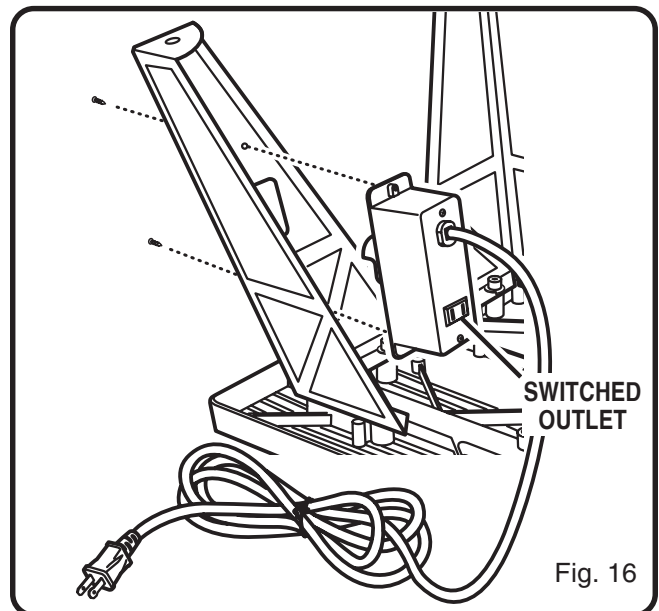

OPERATION

PERFORMING A ROUTING OPERATION

See Figure 16.

Follow these directions to perform a routing operation.

- Read the entire *Operator's Manual*.
- Adjust the cutter guard so that it will not come in contact with the workpiece or cutter during a cutting operation.
- Adjust the infeed fence to support the uncut workpiece and adjust the outfeed fence to support the workpiece after the cut.

NOTE: The workpiece must always be tight against the fence, unless you are using a ball-bearing piloted cutter. Additionally, it may be necessary to remove the center fence plate (with Ryobi logo) if using large cutters.

- Reconfirm that all router adjustments are securely locked before connecting the router table to a power source.
- Feed the workpiece from right to left with the cutter located in the fence opening.

⚠ WARNING:

The direction of feed for the workpiece is always against the sharp edges of the cutter and therefore into the rotation of the cutter. Failure to heed this warning can result in serious personal injury.

⚠ WARNING:

When operating the router with the router table, the router must only be plugged into and controlled by the router table switched outlet. To reduce the risk of serious personal injury, never connect the table mounted router into another power source.

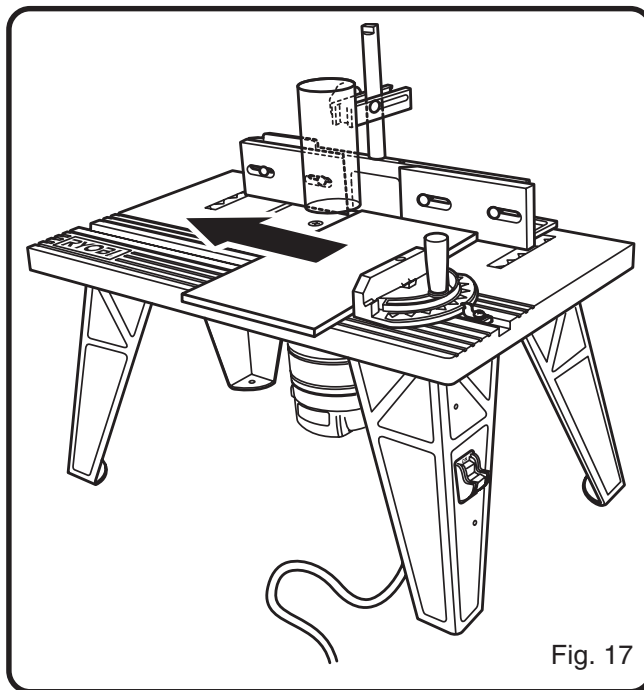

MAINTENANCE

⚠ WARNING:

When servicing use only identical Ryobi replacement parts. Use of any other parts may create a hazard or cause product damage.

GENERAL

Avoid using solvents when cleaning plastic parts. Most plastics are susceptible to damage from various types of commercial solvents and may be damaged by their use. Use clean cloths to remove dirt, carbon dust, etc.

⚠ WARNING:

Do not at any time let brake fluids, gasoline, petroleum-based products, penetrating oils, etc. come in contact with plastic parts. They contain chemicals that can damage, weaken, or destroy plastic.

Electric tools used on fiberglass material, wallboard, spackling compounds, or plaster are subject to accelerated wear and possible premature failure, as the

fiberglass chips and grindings are highly abrasive to bearings, brushes, commutators, etc. Consequently, we do not recommend that this tool be used for extended work on these types of materials. If, however, you do work with any of these materials, it is extremely important that you clean the tool frequently by blowing it with an air jet.

⚠ WARNING:

Always wear safety goggles or safety glasses with side shields during power tool operation or when blowing dust. If operation is dusty, also wear a dust mask.



OPERATOR'S MANUAL

ROUTER TABLE

RT101 - DOUBLE INSULATED

EXTENSION CORD CAUTION

When using a power tool at a considerable distance from a power source, be sure to use an extension cord that has the capacity to handle the current the tool will draw. An undersized cord will cause a drop in line voltage, resulting in overheating and loss of power. Use the chart to determine the minimum wire size required in an extension cord. Only round jacketed cords should be used.

When working with a tool outdoors, use an extension cord that is designed for outside use. This is indicated by the letters "WA" on the cord's jacket.

Before using any extension cord, inspect it for loose or exposed wires and cut or worn insulation.

Cord Length	Wire Size (A.W.G.)					
	0-2.0	2.1-3.4	3.5-5.0	5.1-7.0	7.1-12.0	12.1-16.0
25'	16	16	16	16	14	14
50'	16	16	16	14	14	12
100'	16	16	14	12	10	—

CAUTION: Keep the extension cord clear of the working area. Position the cord so that it will not get caught on lumber, tools or other obstructions while you are working with a power tool.

***Used on 12 gauge - 20 amp circuit.*

• SERVICE

Now that you have purchased your tool, should a need ever exist for repair parts or service, simply contact your nearest Ryobi Authorized Service Center. Be sure to provide all pertinent facts when you call or visit. Please call 1-800-525-2579 for your nearest Ryobi Authorized Service Center. You can also check our Web site at www.ryobitools.com for a complete list of Authorized Service Centers.

• MODEL NO. AND SERIAL NO.

The model number and serial number of this product are found on the label attached to the front leg. Please record the serial number in the space provided below.

• HOW TO ORDER REPAIR PARTS

WHEN ORDERING REPAIR PARTS,
ALWAYS GIVE THE FOLLOWING INFORMATION:

- MODEL NUMBER RT101
- SERIAL NUMBER _____

RYOBI TECHNOLOGIES INC.

1428 Pearman Dairy Road Anderson, SC 29625
 Post Office Box 1207 Anderson, SC 29622
www.ryobitools.com
 Phone 1-800-525-2579